

The bombsight war: Norden vs. Sperry

*As the Norden bombsight helped write World War II's aviation history,
The less-known Sperry technology pioneered avionics for all-weather flying*

Contrary to conventional wisdom, Carl L. Norden -- inventor of the classified Norden bombsight used in World War II -- did not invent the only U.S. bombsight of the war. He invented one of two major bombsights used, and his was not the first one in combat.

That honor belongs to the top secret product of an engineering team at Sperry Gyroscope Co., Brooklyn, N. Y. The Sperry bombsight out did the Norden in speed, simplicity of operation, and eventual technological significance. It was the first bombsight built with all-electronic servo systems, so it responded faster than the Norden's electromechanical controls. It was much simpler to learn to master than the Norden bombsight and in the hands of a relatively inexperienced bombardier its targeting was at least as accurate. And the autopilot that made it work so effectively became the basis for decades of commercial and military aircraft.

Yet although the U.S. Government authorized Sperry to construct a 186,000-square-meter plant in Great Neck on New York's Long Island to manufacture the bombsight and autopilot, the Army canceled the Sperry contracts less than a year after the plant's opening and handed the business to Norden and other companies. Furthermore, declassified documents, plus recollections from some of the principals, show that the design of the final Norden bombsight for which a patent was applied for in 1930 but not issued until 1947 incorporated many of the central improvements pioneered by engineers at Sperry.

How were the Norden and Sperry bombsights invented, and how did they compare? If both bombsights were classified, why did the Norden become so famous during World War II that it was even featured in popular movies while the Sperry was comparatively little known? What factors caused the Army's sudden reversal, even with the Sperry device's advantages? Recent synthesis from scattered documents and interviews with some of the surviving principals lend some insight into these questions.

The precision-bombing problem

Before the Norden and Sperry bombsights, accurate high altitude bombing was considered impossible. Strategists thought of bombers as unstable artillery gun platforms. In the 1930s, comparatively simple mechanisms guaranteed fair accuracy in hitting targets from altitudes below 5000 feet (1.5 kilometers). But at heights above the effective range of anti-aircraft guns, aircraft moved too fast for normal calculations of firing data.

The problem of calculating in real time the proper point for releasing a bomb was formidable for the equipment then in use. A bomber traveled rapidly in three dimensions and rotated about

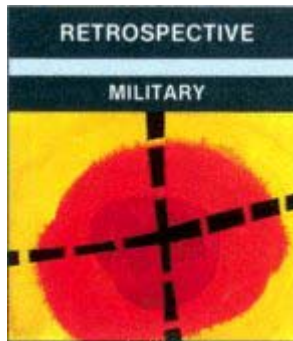

three axes, and was often buffeted by air turbulence. The path of the dropped bomb was a function of the acceleration of gravity and the speed of the plane, modified by altitude wind direction, and the ballistics of the specific bomb. The bombardier's problem was not simply an airborne version of the artillery-gunner's challenge of hitting a moving target; it involved aiming a moving gun with the equivalent of a variable powder charge aboard a platform evading gunfire from enemy fighters.

Originally, bombing missions were concluded by bombardier-pilot teams using pilot-director indicator (PDI) signals. While tracking the target, the bombardier would press buttons that moved a needle on the plane's control panel, instructing the pilot to turn left or right as needed. The pilot had to maintain straight and level flight at the precise altitude and airspeed the bombardier had predetermined for the mission. If the pilot allowed those factors to vary, it would upset the bombardier's efforts to track the target; similarly, if the bombardier operated the azimuth tracking of the bombsight unsteadily, the wavering PDI signals would cause the pilot to fly the plane inaccurately.

It took expert pilots and expert bombardiers working in harmony to target a bomb accurately. And in the heat of combat, that ideal combination was the exception rather than the rule.

Norden takes up the challenge

Carl L. Norden began studying bombing problems in 1921 as a consultant to the U.S. Navy. He had been a Navy consultant on different projects since 1915. For the four years before that, he was an engineer working on ship gyro-stabilizers with the newly formed Sperry Gyroscope Co., and continued as a consultant to Sperry through World War I.

In 1923, Norden went into partnership with another Navy consultant, a former Army colonel named Theodore H. Barth, who provided valuable know-how in sales. Over the next five years, Norden designed bombsights, and Barth built and tested prototypes from Norden's top secret drawings. In 1928, Norden and Barth received their first order from the Navy for 40 bombsights. At that point the two incorporated as Carl L. Norden Inc.

The Norden company delivered its first prototype of its Mark XV bombsight to the Navy in 1931. To make the bombsight's telescope independent of the buffeting of the plane, it was hung from gimbals (ring-shaped bearings that allowed the telescope to point in any direction and remain level when the plane banked). Inside the sight were two dc-powered gyroscopes one for vertical orientation and one for azimuth reference. Both spun at 7800 revolutions per minute. Through an electromechanical servo mechanism similar to those that operated ship stabilizers, the

azimuth gyro steadied the bombsight optics in the horizontal plane so the crosshairs could be synchronized with the plane's approach.

The Norden design had at least four significant problems. First, the carbon dc brushes wore out and had to be replaced frequently; moreover, carbon dust from the wearing brushes would settle into the sensitive gimbal bearings, increasing friction, and necessitating the repeated cleaning and oiling of the precision bearings.

Second, accurate leveling of the vertical gyro was a tricky procedure' especially in rough air, as it required manual setting of two liquid levels like the bubble in a carpenter's level. The process took 510 seconds, a significant fraction of the bombing run.

Third, both the azimuth and range operating knobs were on the right hand side of the bombsight, making simultaneous two-hand sighting on a target almost impossible.

Fourth, the angular freedom of the vertical gyro was such that in rough air the gyro would hit the limits and tumble off its axis of rotation, losing the bombing run.

In spite of the Norden bombsight's imperfections, it performed so much better than any other sight available in the early 1930s that it was quickly adopted by the Navy for all its bombers. Furthermore, the Navy designated Carl L. Norden Inc. as a dedicated source (meaning the Navy purchased bombsights exclusively from Norden, and Norden supplied bombsights only to the Navy. In effect, this made the Norden company a manufacturing arm of the Navy under the Norden name.

Meanwhile, Sperry Gyroscope Co., which had been founded by Elmer Sperry in 1909, had begun designing and building bombsights as a natural outgrowth of its development of gyroscopes for commercial and military aircraft and ships. As early as 1914, when Norden had been on the payroll for three years, Sperry's company had built and was granted a patent for a vertically stabilized bombsight that relied on a vertical gyro assembly driven with dc power. The company went on to develop improved models of this first synchronized sight in 1915, 1918, 1924, 1927, 1929, 1930, and 1933, culminating in a model called the Sperry O-1. But as in the Norden sight, the Sperry gyros had significant problems. Moreover, there was no market for the Sperry bombsights until the Army began having procurement problems with the Norden company in 1936.

The politics of procurement

In the 1930s, the U.S. Army was building up its own airborne fighting arm, known as the General Headquarters (GHQ) Air Force, which had been established in 1922. The Army was structured so that the GHQ Air Force had to arrange training and procure supplies through another arm, the Army Air Corps.

The GHQ Air Force, as impressed with the Norden bombsight as the Navy, made it standard equipment on its own bombers by 1934. But because the Norden company was a dedicated source to the Navy, the only way the Army Air Corps could get Norden bombsights was by ordering them through the Navy, a pass-along arrangement that complicated design development and delivery.

Since the Norden bombsight had been developed primarily for the medium altitudes and slow speeds of small Navy flying boats, such as the PBY bombers, it needed to be modified for the higher speeds and extremely high and low altitudes of the heavy, long-range Army GHQ Air Force bombers. For Air Force purposes, the Norden's optical field of the telescope was too

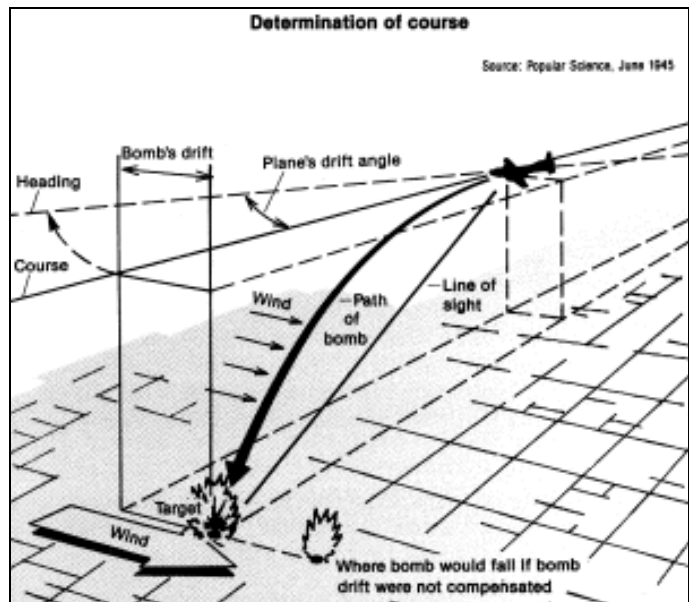
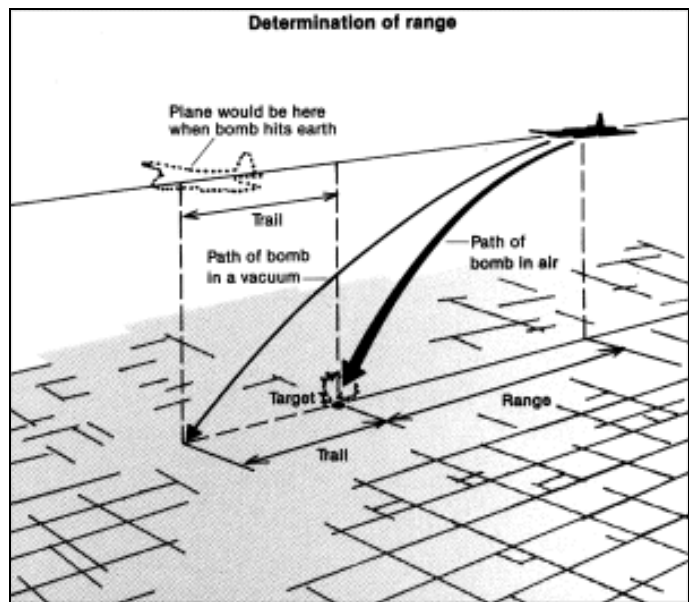

A bombsight had to determine in real time both the range and the course of the plane so as to calculate the proper moment for releasing a bomb. It had to compensate for air resistance, which caused the bomb to trail behind the plane (top), and cross winds, which made it drift downwind to the side of the plane's path (bottom). Other factors included the bombs ballistics and the target's altitude, which affected, the time of fall.

limited, giving insufficient forward and thwartship vision. The Norden bombsight also did not allow bombs to be accurately targeted if the plane were descending in a glide a maneuver preferred to level flight during bombing runs because changing altitude made the bomber a more elusive target for antiaircraft guns and its trail settings were too limited to accommodate the wind resistance encountered by the faster Air Force planes. These shortcomings could only be overcome if Air Force bombardiers fudged the data they entered into the bombsight by levers and knobs.

The design problems became moot, however, when despite the pressure from both Navy and Army, Carl L. Norden Inc. could not deliver. One reason may have been the fact that the firm relied on old-world artisans in its various plants to manufacture the

Norden Mark XV by hand, fitting the parts according to qualitative tolerances as "free-running fit, no play.

In January 1936, the Navy suspended all deliveries of the Norden sight to the Army Air Corps until the Navy's own requirements were satisfied. At that point, the commander of the GHQ Air Force, Major General Frank M. Andrews, expressed his concern in a memo to the Chief of the Air Corps and to the Navy. He then openly encouraged the Sperry Gyroscope Co. to develop the O-1 bombsight to meet Air Force specifications.

On The Drawing board

By this time, 1937, a new type of gyroscope had been developed by Orland E. Esval, one of Sperry's foremost electrical engineers. Since the gyroscopic effect is due to the moment of inertia of the wheel, the greatest effect is obtained by a massive gyro spinning fast. Esval's new gyro had twice the mass of the one used in the then-current Sperry O-1 bombsight, and about the same weight as the vertical gyro in the Norden Mark XV. However, Esval's gyro was designed to spin at 30 000 rpm nearly four times faster than the Norden's gyros. The increased gyroscopic effect overcame friction in the gimbal bearings that was a source of precession (a slow gyration of the rotation axis) and failure.

Carl Frische, then a young development engineer who years later became Sperry's president, assisted Esval in developing the first self-erecting system for the new vertical gyro. When engaged, the self-erecting system would automatically find the exact vertical, eliminating the necessity for a pilot and bombardier to spend time in a bombing run aligning liquid levels. Esval and Frische designed the self-erecting system so that it could be turned off during banking maneuvers, so as not to precess the gyro to a false vertical; when switched on again after the aircraft returned to level flight, it would again automatically seek the true vertical.

Esval's high-speed gyro and Frische's self-erecting system, along with an optical gyro-balancing machine that speeded manufacture, dramatically improved the vertical tracking accuracy of Sperry's O-1 bombsight, later designated the S-1. Next, they turned a second gyro wheel assembly on its side to make an azimuth gyro.

Esval and Frische also decided to treat the azimuth gyro as a sensor only, to eliminate the physical linkage that in the Norden bombsight was a source of friction. To do this, they mounted an electromagnetic pickoff on a nonspinning ring that was centered on the spinning rotor and was controlled by the azimuth servo motor. When aircraft movements caused the slightest angular deviation of the gyro's from the plane's axes, the E-pickoff generated electric signals that, when amplified, controlled a servomechanism that compensated for the plane's movement and thus stabilized the bombsight optics in azimuth. This may have been the first use of closed-loop amplifiers.

Esval's new gyros were self-lubricating and induction-powered, eliminating the dc brushes that caused carbon dust. This innovation, however, required the new gyro to have its own ac power source, because in the late 1930s U.S. airborne instrumentation ran only on dc power or on vacuum suction generated through venturi tubes mounted outside the cockpit. The Army Air Corps was so inspired by the performance of the Sperry bombsight that it soon adopted induction electrical systems for aircraft, which later facilitated radio instrumentation. The Air Corps settled on a 400-hertz electrical system that, accordingly, spun the new gyros at a somewhat reduced rate of 24 000 rpm. Although there was some loss in gyroscopic momentum, the

instrument still spun more than three times faster than the Norden Mark XV's gyros.

In 1940 and 1941, the Norden XV bombsight was installed in Air Corps B-17 bombers. The Sperry S-1 was installed in B24Es used by the 15th Air Force in the Mediterranean area and in lendlease B-24s supplied to the British Royal Air Force (RAF), since the Navy refused to release Norden sights to foreign governments.

A modified Sperry O-1 bombsight first saw combat on April 30, 1941 from a British bomber, more than six months before the United States entered the war with its Norden-equipped planes.

"The target was a heavily armed yet small Nazi supply ship of 700-800 tons" near Tyboron, Denmark, recalled John Mallinson, a former RAF wing commander who flew on that first mission. "Our squadron was the 220 Coastal Command based at Thornaby, Yorkshire. The Sperry had been installed in a Lockheed Hudson Mk V, and we made our approach at 8000 ft [2.4 km]. The German supply ship looked like a tiny speck from 8000 ft, but with the Sperry bombsight, our bombardier and Wing Commander Charles Dann dropped only one salvo, and our bombs hit squarely across the ship's stern on the first pass."

The first all-electronic autopilot

The precision targeting made possible by the bombsights demanded a higher level of precision in maintaining a plane's course, attitude, altitude, and trim--far beyond what could be attained with a bombardier-pilot team or commercial autopilot.

Some of the B-17s in the late 1930s came equipped with a Sperry A-3 commercial autopilot. The gyros in the A-3 sensed only simple angular displacement of the aircraft from the desired course. It used pneumatic hydraulic servo systems that were sluggish, and since there was no measure of velocity or acceleration, the system tended to overcompensate in rough air and thus oscillate.

The Norden company developed an autopilot called the stabilized bombing approach equipment (SBAE), also based upon the earlier displacement only signal technology of commercial auto pilots. The Norden SBAE's mechanically sliding trolley-contact electric servos had simple dashpots or shock absorbers that produced negative clamping to eliminate oscillations, but this also showed response either to wind buffeting or to commands from the bombsight. The result was flight control no better than that of the Sperry A-3 commercial autopilot.

For the new Sperry S-1 bombsight, Frische invented the first all-electronic autopilot, the A-5. It was based on three dual element vacuum tube amplifiers, each corresponding to a different axis in the aircraft's control system: roll, pitch, and yaw. The tubes had been subjected to accelerated life testing, temperature cycling, and vibration to ensure unprecedented reliability.

Each tube amplified the weak signal measured from the autopilot's own set of sensors on the high-speed induction gyros. More important, in addition to the displacement-error signal, the A-5 autopilot adjusted for the first and second time derivatives (the velocity and acceleration with which the aircraft departed from the base reference signal). The amplified signals controlled independent electro hydraulic servomechanisms, providing fast response for stabilizing the aircraft.

This resulted in a system that was critically damped, thus allowing for the aircraft's inertia, and was much more responsive than the electromechanical technology to wind gusts and command signals from the bombsight.

Controls for the Sperry S-1 bombsight were electrically connected to the A-5 autopilot. Once the bombing run was begun, the pilot turned the aircraft over to the bombardier, who then flew

the bomber by tracking the target through the bombsight. When the bombsight determined that the release point had been reached, it alerted the bombardier and dropped the bomb. The combination of

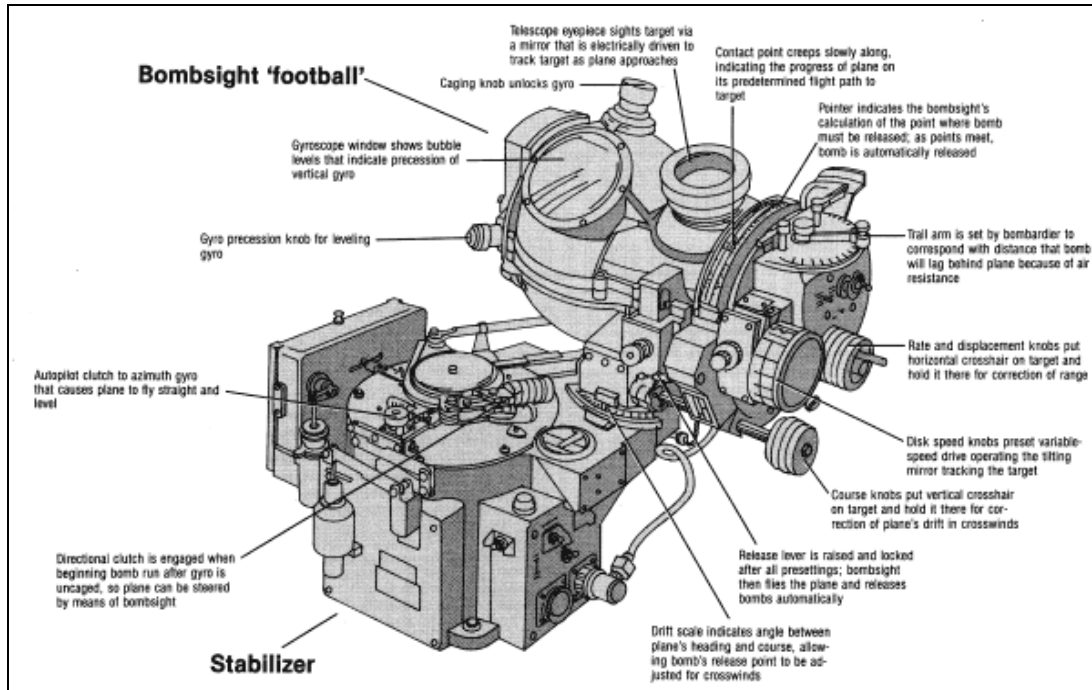

Norden Mark XV bombsight (above) had all its controls on the right-hand side, slowing the bombardier's adjustments, while the Sperry S-1 bombsight (below) had controls on both sides, allowing range and course to be adjusted simultaneously. The Norden's top section, dubbed the "football," was removable; it contained the vertical gyro while the azimuth gyro was housed in the stabilizer. In the Sperry the azimuth gyro (not shown) was in a box bolted to the far side. The Sperry bombsight was mounted on shock absorbers to prevent vibration from the plane's engines from shaking the telescope optics; the Norden was not.

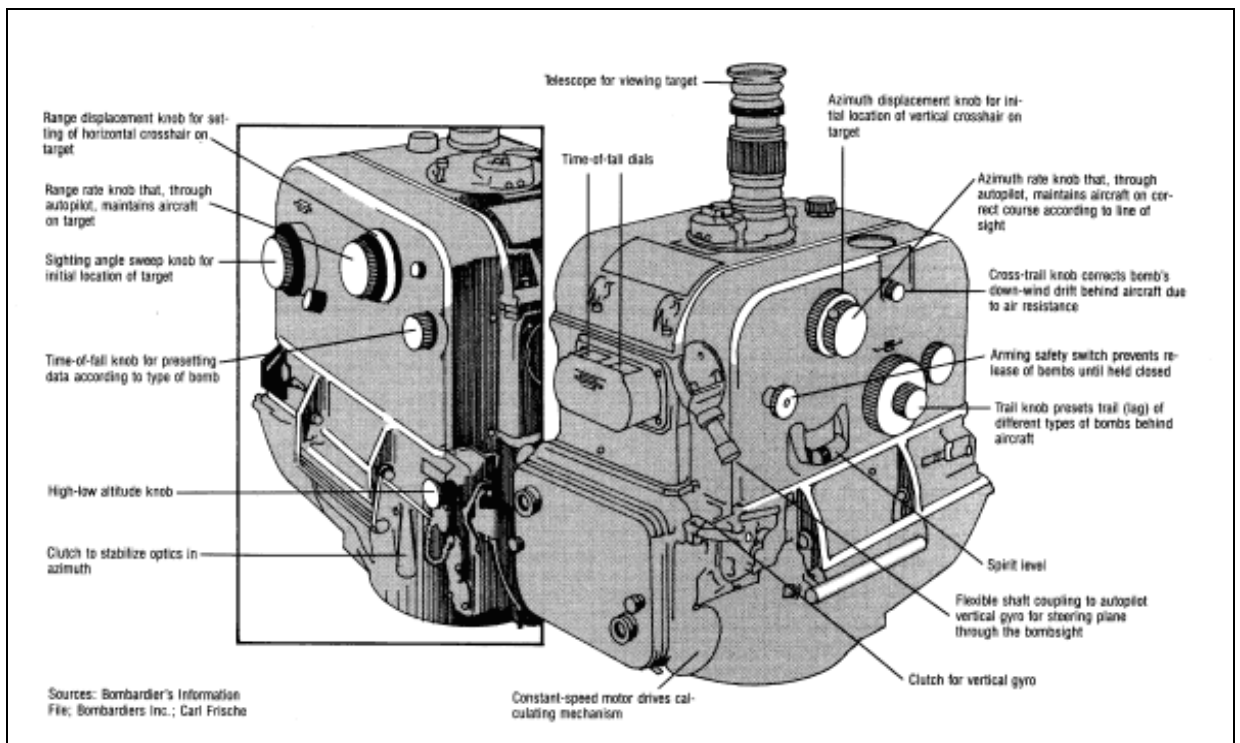

the two Sperry mechanisms into one system led to unprecedented accuracy in targeting while in combat.

The officials of the U.S. Army Air Corps were so impressed with the Sperry A-5 autopilot's performance that on June 17, 1941, the company was awarded a government contract authorizing the 186, 000 square-- meter plant in Great Neck, N. Y., for manufacturing the A-5 autopilot and S1 bombsight. The Air Corps also issued a Teletype message noting its decision "that in the future all production models of bombardment airplanes be equipped with the A-5 Automatic Pilot and have provisions permitting the installation of either the M-Series [Norden] Bombsight or the S-1 Bombsight.

Rivalry and salesmanship

The Norden company was not pleased with Sperry's growing competition. As early as July 29, 1937, when the Air Force's Major General Andrews began encouraging Sperry to develop a bombsight for Air Force planes because Norden could not meet the demand, a conference was held at the Norden company in New York City between Navy, Air Corps, and Norden personnel. According to the meeting report, Norden's president, Theodore H. Barth, "spoke somewhat disparagingly of the Sperry Company" and "stated he was very much grieved that the Air Corps was purchasing...an inferior sight" from Sperry, and offered to set up a separate factory exclusively for the Air Corps a suggestion the Navy did not accept.

When the Air Corps asked Norden to cooperate with Sperry to make a Sperry autopilot standard equipment even on Norden equipped planes, the company balked, even though Sperry signed an agreement that it would not "take any steps in the way of the filing of suits, etc., regarding the possible infringement of patents on the part of the Norden Company that may be incorporated in the Norden Sight."

To get around the stalemate, in January 1942 the Air Corps contracted for autopilots with the Honeywell Regulator Co., Minneapolis, Minn. The Honeywell autopilot, called the C-1, was based on the Norden SBAE gyros, but incorporated the electronic rate circuits and servos from the Sperry A-5. At the request of the Air Corps, Honeywell engineers went to Sperry for information and a demonstration of the Sperry A-5, and the Air Corps acquired a manufacturing license from Sperry so that Honeywell would have a free hand in incorporating certain features.

Meanwhile, Norden's Barth was working hard to ensure Norden's primacy in military procurement. Barth was a personable and flamboyant salesman for the company, with extensive contacts in both the Navy and the Army, all of whom he enthusiastically wined and dined. Even though by World War II the Norden bombsight's classification had been reduced from top secret to confidential, Barth and others within Norden skillfully cultivated a "top secret" mystique about the Norden bombsight that exists to this day. During wartime the top portion of the sight, dubbed the "football," was removed from the bottom stabilizer when the aircraft was on the ground, and was escorted by armed guards to the Norden Lockup on each base. Bombardiers had to swear an oath "to protect the secrecy of the American bombsight, if need be with my life itself." Norden bombardiers would often say that they could drop a bomb into a pickle barrel from 20 000 ft (6 km), and legend was, they complained that they were not told which pickle to hit.

Another story circulated that the reticle of the Norden was so fine that it required especially fine human hair from one blonde woman named Mary Babnick, who was known as Arcadia Mary because she taught dancing to soldiers at the USO's Arcadia Ballroom at the Pueblo Army Air Base in Colorado. Even the 1940s radio serial "Jack Armstrong, the All American Boy" offered as a premium the Secret Norden Bombsight—a wooden box that allowed sighting through a mirror arrangement down to toy Nazi U-boats, and then dropped little red bombs on the cardboard cutouts.

The Sperry bombsight, on the other hand, not only was classified top secret; it was also company policy that no one tell anyone, without the need to know, that the Sperry Gyroscope Co. even made bombsights. There was no publicity, no stunts. Sperry's chief military marketing representative, Fred Vose, was a more sober personality than Norden's Barth, but forged strong connections with the Air Force through Major General Andrews. In April 1942, however, Vose was killed in an airplane crash near Salt Lake City, Utah, and in early 1943 Andrews was lost over Iceland. With their deaths, Sperry lost two strategically placed advocates—one in the company and the other at the customer.

The Navy also had reservations about Sperry's status as a multinational commercial company, which, before the war, had licensees not only in London, but also in Germany and Japan. "The Tokyo thing made them boil," Frische recalled. "We were practically accused of being disloyal." Barth, in the meantime, pointed out that as a dedicated source Norden could not only "devote its entire attention to the interests of the Government" but also "maintain a high degree of secrecy" not possible with an "international organization" engaged in "world trade."

Moreover, Norden had a 10-year head start over Sperry in bombsight contracting, and was well established with the Navy in 1937 when the Air Force began encouraging Sperry to build a new sight. In addition, Frische noted, before Esvall's high-speed induction gyro was installed in the O-1 to create the S-1 sight, "our gyros and azimuth servos were not very good. We almost flunked out, and that aura may have stuck with us."

In any event, by May 1943, Navy officials—after years of complaining about a bombsight shortage—said they were concerned about having a bombsight surplus. One month later, the Navy decided to dispose of surplus facilities with the least experience. General Barney M. Giles, chief of air staff of the GHQ Air Force, recommended on Aug. 4, 1943, that the Air Corps standardize on the Norden. One week later, Major General Davenport Johnson, commander of the second Air Force, a training operation in Colorado Springs, Colo., sent a letter to the commanding general Henry Harley ("Hap") Arnold of the GHQ Air Force, claiming that the Sperry equipment was not as accurate as the Norden. Giles thus recommended that all contracts for Sperry S-1 bombsights and A-5 autopilots be canceled immediately.

On Nov. 22, 1943, the Air Corps' Brigadier General Edwin S. Perrin directed that instructions be issued to the materiel command "to proceed immediately with the cancellation of all contracts for Sperry S-1 bombsights and A-5 autopilots" with Sperry and Sperry's licensed contractors, International Business Machines and National Cash Register. The Sperry work on the bombsights and autopilots at the plant was shut down, some 2600 remaining bombsights were destroyed, their instruction manuals burned, and tens of thousands of autopilots were put in storage.

Through the end of the war, the Air Corps' standard equipment was the Norden bombsight and Honeywell C1 autopilot—both incorporating technology developed at Sperry.

The bombsights' legacies

Postwar evaluation showed that precision high-altitude bombing was much less effective than believed during the war. Although the visual bombsights worked, the generally poor weather over Europe interfered with their success. By the end of World War II, both radar-guided and television guided bombs were being developed.

Although based on 1914 through 1920s technology, the Norden was important because of its popularity and its role as a morale booster and ultimately because it did equip three quarters of U.S. bombers. Although less well known, the Sperry sight was based on later technology that ultimately facilitated the development of avionics for all-weather flying. Its legacy lasts to this day, in electronic autopilots and in the gyro syn compass that is still the standard heading reference on most commercial and military aircraft.

To probe further

Background to the invention and procurement of both the Norden and Sperry bombsights can be found in unpublished memoranda and policy statements by the Army Air Corps, the Navy, and Carl L. Norden inc., in the U.S. Air Force Historical Research Center at Maxwell Air Force Base, Montgomery, Ala. Particularly valuable was the Case History of Norden Bombsight and C-1 Automatic Pilot, declassified in January 1945 by the History Office of the Air Technical Service Command, Wright Field, Dayton, Ohio.

Elmer Sperry: Inventor and Engineer, by Thomas Parke Hughes (Johns Hopkins Press, Baltimore, Md., 1971), outlines the early relationship between Carl Norden and Sperry.

Two contemporary articles published in the AIEE Transactions detail technical specifications about the Sperry mechanisms. "Electric Automatic Pilots for Aircraft," by Percy Halpert and Orland E. Esval, published November 1944, vol. 63, pp. 861-65, describes the theory of the Sperry A-5 autopilot; "The Gyro syn Compass," by Esval, also published November 1944, pp. 857-60, announced what has since become the standard heading mechanism in commercial aircraft, which evolved from the induction driven gyros developed for the Sperry bombsight.

About the author

Loyd Searle (M) is president of High Tech Promotions Inc., in Woburn, Mass., an advertising, marketing and consulting firm specializing in electronic and high-technology products. Before founding the company in 1981, Searle was sales manager and director of marketing for several thin-film and instrumentation companies in New York and Massachusetts. In addition to engineering, his background includes degrees in communications and psychology. He also enjoys restoring antique cars.

The author would like to express gratitude to Bob Collings, director of the Collings Foundation, Stow, Mass; Orland E. Esval (F), now retired and living in Banner Elk, N.C.; Carl A. Frische (F), now retired and living in Scottsdale, Ariz; Gerald Hanson, former head of Sperry production engineering, now retired and living in Glen Head, N.Y.; E.C., "Ned" Humphreys, Col. USAF Ret. Executive director of Bombardiers Inc., Eagle Harbor, Mich; former Royal wing commander Jon D. Mallinson, now retired and living in Hampshire, England; Leroy Newby, lecturer and author, now living in Webster City, Iowa; and others for their time and historical documents.



The Sperry bombsight and A-5 autopilot computer system forged the way for new class of avionics and pioneered all weather flying. It was the first bombsight computer system built with all-electronic servo systems, and closed looped amplifiers so it responded faster than any other system of that time. It's initial use marked the first example of precision bombing on April 30, 1941, when a British bomber, a Lockheed Hudson Mk V, near Tyboron, Denmark dropped only one salvo, and bombs hit squarely across the ship's stern on the first pass.